

model: **1367 Series**  
Motorized Carousel

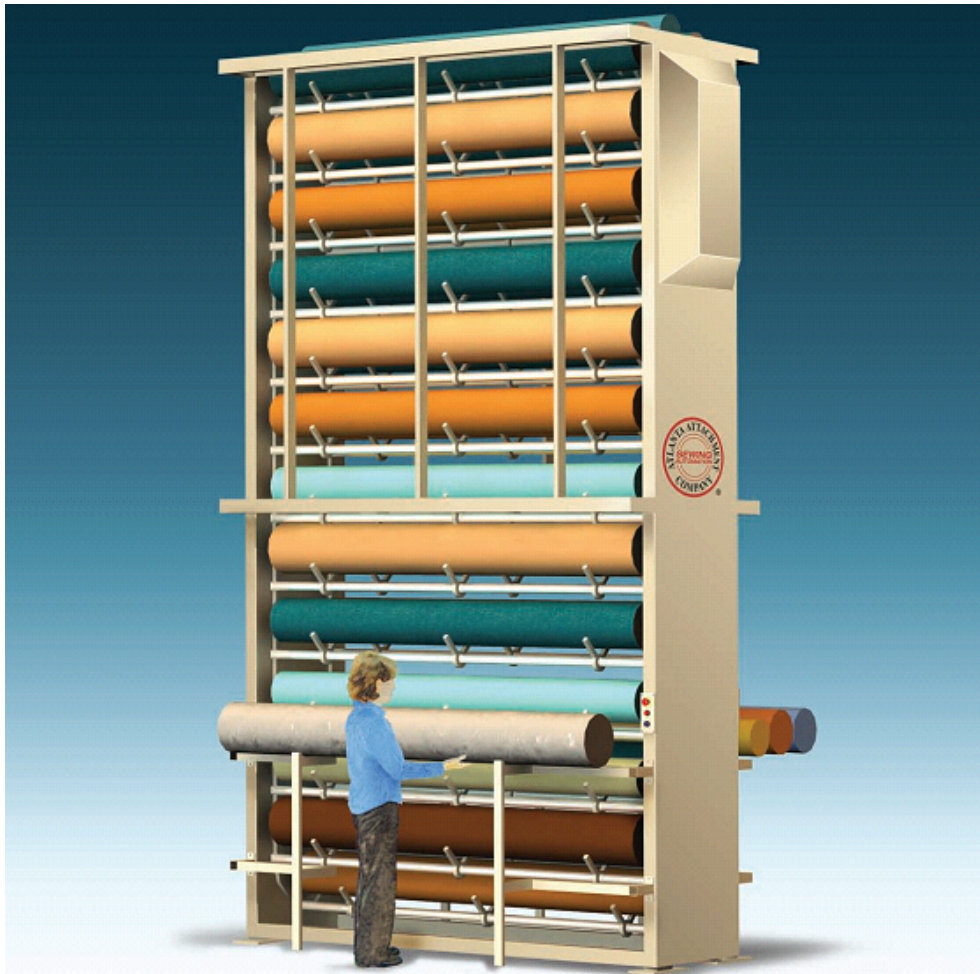

## Installation, Operating Manual

"Sudden Service"



From the library of: Diamond Needle Corp

### Atlanta Attachment Company

362 Industrial Park Drive  
Lawrenceville, Georgia 30046  
Phone: (770) 963-7369



**One-Stop Shopping**  
for Expendable Replacement  
Parts for AAC & Other Bedding  
Equipment Suppliers  
Toll Free: 1-866-885-5100  
[www.atlantapartsdepot.com](http://www.atlantapartsdepot.com)



---

## Atlanta Attachment Company, Inc.

### Confidential and Proprietary Information

The materials contained herein are confidential and proprietary information of Atlanta Attachment Company. In addition to any confidentiality and non-disclosure obligations that currently exist between you and Atlanta Attachment Company, your use of these materials serves as an acknowledgment of the confidential and proprietary nature of these materials and your duty not to make any unauthorized use or disclosure of these materials.

All materials contained herein are additionally protected by United States Copyright law and may not be used, disclosed, reproduced, distributed, published or sold without the express written consent of Atlanta Attachment Company, which consent may be withheld in Atlanta Attachment Company's sole discretion. You may not alter or remove any copyright, trademark or other notice from copies of these materials.



---

## Atlanta Attachment Company, Inc.

### Información Confidencial y Propietaria

Los materiales contenidos adjuntos son información confidencial y propiedad de Atlanta Attachment Company. Además de cualquier obligación confidencial y de no divulgación que exista actual entre usted y Atlanta Attachment Company, el uso de estos materiales sirve como reconocimiento de la naturaleza confidencial y propietaria de estos materiales y de su deber de no hacer ningún uso desautorizado o acceso de estos materiales.

Todos los materiales contenidos adjunto son protegidos además por la ley de Derechos de Autor de Estados Unidos y no se pueden utilizar, divulgar, reproducir, distribuir, publicar o vender sin el consentimiento escrito expreso de Atlanta Attachment Company. El consentimiento se puede retener en discreción única de Atlanta Attachment Company. Usted no puede alterar o quitar los derechos reservados, la marca registrada o cualquier otro aviso de las copias de estos materiales



**TABLE OF CONTENTS**

**CONFIDENTIAL AND PROPRIETARY INFORMATION.....2**  
**INFORMACIÓN CONFIDENCIAL Y PROPIETARIA .....3**  
**A.- SAFETY PRECAUTIONS .....5**  
**B.- PRECAUCIONES DE SEGURIDAD.....6**

**1.- INSTALLATION.....7**  
 1.1.- TECHNICAL DATA .....7  
 1.2 .- INSTALLATION INSTRUCTIONS.....8

**2.- OPERATING .....ERROR! BOOKMARK NOT DEFINED.**

STATEMENT OF WARRANTY .....12  
*Manufactured Products* .....12  
*Terms and Conditions:*.....12  
*What Is Covered*.....12  
*What Is Not Covered*.....12  
 DECLARACIÓN DE GARANTÍA.....13  
*Productos Manufacturados*.....13  
*Términos y Condiciones:* .....13  
*Lo Que Está Garantizado* .....13  
*Lo Que No Está Garantizado*.....13  
 NOTES .....14

From the library of: Diamond Needle Corp



## a.- Safety Precautions



It is important that the machine operator read this manual and is familiar with all the functions and safety concerns of the unit before operating.



### General

The safety guidelines mentioned in this manual cover the entire product line of Atlanta Attachment Company. Some warnings and/or instructions may not apply to this particular unit.

All maintenance should be performed by a qualified service technician.



### Electrical

- Electrical connection requires 220vAC, 5 Amp, 50/60 Hz Single Phase
- Disconnect the power source before threading or replacing the needles.
- Disconnect the power source before leaving the machine unattended.
- Disconnect the power source before removing or replacing parts or making adjustments and/or performing maintenance.
- Disconnect the power source before opening electrical control panels.



### Pneumatics

Air supply requires 70-80 PSI, 2 SCFM avg.

#### Air Cylinders

- Keep hands away from pneumatic cylinders at all times.
- Disconnect air supply before servicing air cylinders.



### Knives

- This machine may utilize knives and/or thread cutters that may activate automatically.
- Keep hands away from knife blades at all times.
- Disconnect power source and air supply before replacing damaged blades.

### Conveyors

- This unit may include material conveyors.
- Keep hands away from belts.
- Keep hands away from motors and pulleys used to power the conveyors.



### Pullers

- This unit may include pullers used to pull material into a sewing head, knife, etc.
- Keep hands away from pullers.



### Sewing Heads

- Keep hands and all other objects away from needles.
- Disconnect power source and air supply before making adjustments to the sewing head, replacing needles, threads, bobbins, etc.



## b.- Precauciones de Seguridad



**Es importante que el operador lea este manual y se familiarice con las funciones normas de seguridad antes de operar el equipo.**



### General

Las pautas de seguridad mencionadas en este manual cubren la línea entera de productos de Atlanta Attachment Company. Algunas advertencias e instrucciones pueden no aplicarse a esta unidad particular.

Todo mantenimiento debe ser realizado por un técnico calificado de servicio.



### Eléctrico

- La conexión eléctrica requiere 220V AC, 5 amperios, monofásico de 50/60 hertzios
- Desconectar la fuente de energía antes de enhebrar o substituir las agujas.
- Desconectar la fuente de energía antes de dejar la máquina desatendida.
- Desconectar la fuente de energía antes de quitar o de substituir piezas o de hacer ajustes y/o de realizar mantenimiento.



### Neumática

El suministro de aire requiere 80 PSI, average de 2 SCFM.

### Cilindros del aire

- Mantener las manos siempre lejos de los cilindros neumáticos.
- Desconectar el suministro de aire antes de mantener los cilindros del aire.



### Cuchillas

- Esta máquina puede utilizar cuchillas y/o los cortadores del hilo que se pueden activar automáticamente.
- Mantener las manos lejos de las láminas de cuchillas siempre.
- Desconectar la fuente de energía y el suministro de aire antes de substituir las cuchillas dañadas.



### Transportadores

- Esta unidad puede incluir transportadores de materiales.
- Mantener las manos lejos de las correas de las correas.
- Mantener las manos lejos de los motores y de las poleas usadas para accionar los transportadores.



### Ruedas de Tensión

- Mantener las manos lejos de las Ruedas de Tensión.

### Cabezas de costura

- Mantener las manos y el resto de los objetos lejos de agujas.
- Desconectar la fuente de energía y el suministro de aire antes de hacer ajustes a la cabeza de costura, substituyendo agujas, los hilos, las bobinas, el etc.



# 1.- Installation.



It is important that the machine operator read this manual and is familiar with all the functions and safety concerns of the unit before operating.

## 1.1.- Technical Data

- Motorized Carousel
- Standard machine heights from 10' to 24'
- Easy to operate push button controls
- Lifetime sealed bearings (no maintenance)
- Smooth, integrated drive system
- Shielded motors
- Solid pin chain with 2" on-center positioning

Height	Configuration	Qty Rolls
10'	Single	15
	Dual	29
	Triple	44
15'	Single	21
	Dual	41
	Triple	62
20'	Single	28
	Dual	55
	Triple	83
24'	Single	35
	Dual	69
	Triple	104

Standard units are 208 volt, 3 phase

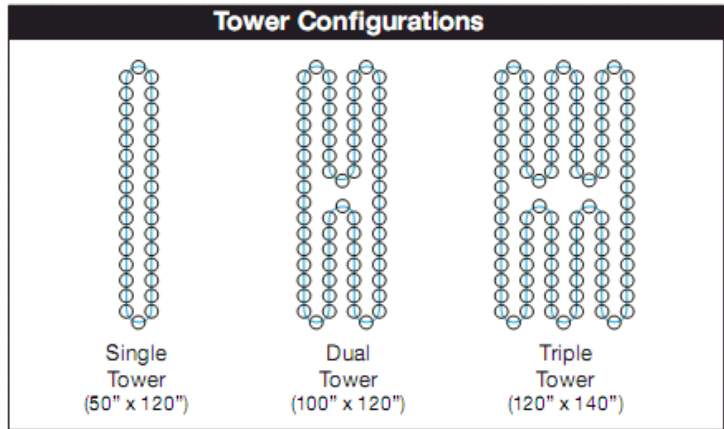

SPECIFICATIONS	
Current (v/ph/hz)	220 3PH 60HZ

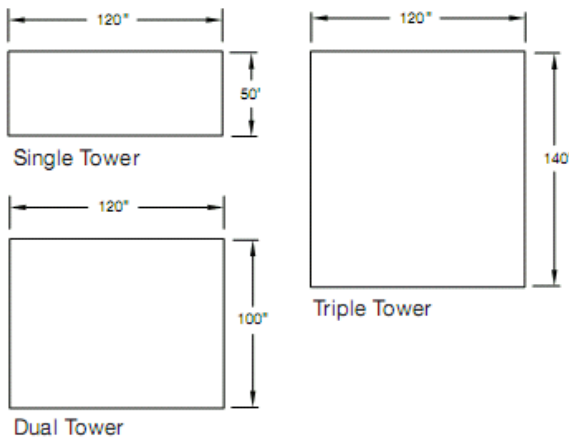

From the library of: Diamond Needle Corp

## 1.2 .- Installation Instructions.

Secure end frames to sling straps at upper cross tube behind drive sprocket. Lift with suitable lifting device (fork lift shown) and lift both frames into vertical position with 110” between legs. Frame with key pad goes on the right facing the infeed of the Laser with key pad on the outside. Center the frames in front of the laser and about 16.5” from Laser frame.



With two frames held in place by lifting devices, bolt in the lower cross beam (the one without the bolts installed in the center bracket).





Install the top cross beam with the center bracket down. Then install the angle supports.



Disconnect the lifting devices.

Installing the cross shaft: Check the height of one of the hanger bolts on the chains on both left and right sides to be sure they are level. If not, rotate one of the chain drive motor pulleys by hand until the bolts are level.

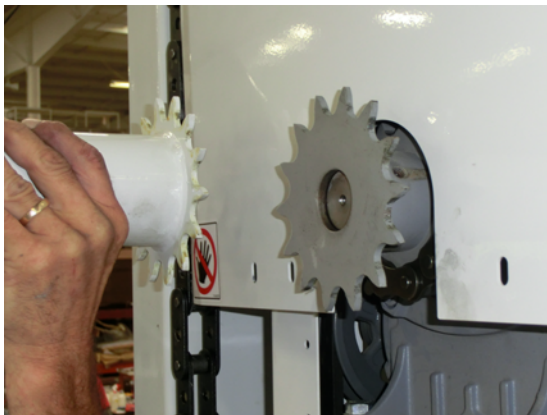

Hold both ends of the cross shaft in position and wrap the chain around the sprockets and secure with master link and cotter pins. There are shims provided for the cross beams if needed to make shaft fit without binding.

Insert the electrical cable from the left side motor into the hole in the bottom of the top cross brace and push it thru to the right side hole. Connect to the right motor matching wire numbers.



Install the upper guards by sliding the bolt heads into the key-hole features on the frame. Install beams with center holes up.



Install the adaptor brackets for the Laser. Reposition the unit as necessary to secure to the Laser with pull pins.

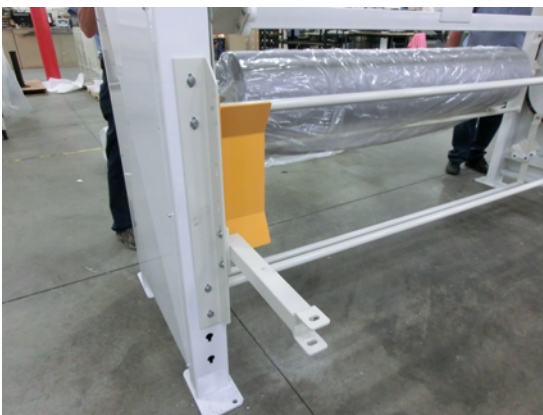

Connect 220v, 3 Ph power to junction box on top of right frame.



Install the support tubes onto the bolts on the chains with two washers inside and one washer and nut outside. Connection should be loose enough for the support tubes to swing freely. Be sure the side with twin rollers faces the yellow stop bracket. Use code “4321\*” to enable the motor control buttons. Buttons will stay “active” for 30 seconds of idle time, then the code must be re-entered.



Install the material rolls onto the tubes and secure with the tapered collars. Center the material on the tubes. Install the tubes into the support cradles.





# Atlanta Attachment Company (AAC)

## Statement of Warranty

### Manufactured Products

Atlanta Attachment Company warrants manufactured products to be free from defects in material and workmanship for a period of eight hundred (800) hours of operation or one hundred (100) days which ever comes first. Atlanta Attachment Company warrants all electrical components of the Serial Bus System to be free from defects in material or workmanship for a period of thirty six (36) months.

### Terms and Conditions:

- AAC Limited Warranty becomes effective on the date of shipment.
- AAC Warranty claims may be made by telephone, letter, fax or e-mail. All verbal claims must be con-firmed in writing.
- AAC reserves the right to require the return of all claimed defective parts with a completed warranty claim form.
- AAC will, at its option, repair or replace the defective machine and parts upon return to AAC.
- AAC reserves the right to make the final decision on all warranty coverage questions.
- AAC warranty periods as stated are for eight hundred (800) hours or one hundred (100) days which ever comes first.
- AAC guarantees satisfactory operation of the machines on the basis of generally accepted industry standards, contingent upon proper application, installation and maintenance.
- AAC Limited Warranty may not be changed or modified and is not subject to any other warranty expressed or implied by any other agent, dealer, or distributor unless approved in writing by AAC in advance of any claim being filed.

### What Is Covered

- Electrical components that are not included within the Serial Bus System that fail due to defects in material or workmanship, which are manufactured by AAC are covered for a period of eight hundred (800) hours.
- Mechanical parts or components that fail due to defects in material or workmanship, which are manu-factured by AAC.
- Purchased items (sewing heads, motors, etc.) will be covered by the manufacturer's (OEM) warranty.
- AAC will assist in the procurement and handling of the manufacturer's (OEM) claim.

### What Is Not Covered

- Parts that fail due to improper usage, lack of proper maintenance, lubrication and/or modification.
- Damages caused by; improper freight handling, accidents, fire and issues resulting from unauthorized service and/or personnel, improper electrical, plumbing connections.
- Normal wear of machine and parts such as Conveyor belts, "O" rings, gauge parts, cutters, needles, etc.
- Machine adjustments related to sewing applications and/or general machine operation.
- Charges for field service.
- Loss of time, potential revenue, and/or profits.
- Personal injury and/or property damage resulting from the operation of this equipment.



# Atlanta Attachment Company (AAC)

## Declaración de Garantía

### Productos Manufacturados

Atlanta Attachment Company garantiza que los productos de fabricación son libres de defectos de material y de mano de obra durante un periodo de ochocientos (800) horas de operación o cien (100) días cual llegue primero. Atlanta Attachment Company garantiza que todos los componentes del Serial bus son libres de defectos de material y de mano de obra durante un periodo de treinta y seis (36) meses.

### Términos y Condiciones:

- La Garantía Limitada de AAC entra en efecto el día de transporte.
- Reclamos de la Garantía de AAC pueden ser realizados por teléfono, carta, fax o correo electrónico. Todo reclamo verbal tiene que ser confirmado vía escrito.
- AAC reserva el derecho para exigir el retorno de cada pieza defectuosa con un formulario de reclamo de garantía.
- AAC va, según su criterio, reparar o reemplazar las máquinas o piezas defectuosas devueltas para AAC.
- AAC reserva el derecho para tomar la decisión final sobre toda cuestión de garantía.
- Las garantías de AAC tiene una validez de ochocientas (800) horas o cien (100) días cual llega primero.
- AAC garantiza la operación satisfactoria de sus máquinas en base de las normas aceptadas de la industria siempre y cuando se instale use y mantenga de forma apropiada.
- La garantía de AAC no puede ser cambiado o modificado y no está sujeto a cualquier otra garantía implicado por otro agente o distribuidor menos al menos que sea autorizado por AAC antes de cualquier reclamo.

### Lo Que Está Garantizado

- Componentes eléctricos que no están incluidos dentro del sistema Serial Bus que fallen por defectos de materiales o de fabricación que han sido manufacturados por AAC son garantizados por un periodo de ochocientas (800) horas.
- Componentes mecánicos que fallen por defectos de materiales o de fabricación que han sido manufacturados por AAC son garantizados por un periodo de ochocientas (800) horas.
- Componentes comprados (Motores, Cabezales, ) son protegidos debajo de la garantía del fabricante.
- AAC asistirá con el manejo de todo reclamo de garantía bajo la garantía del fabricante.

### Lo Que No Está Garantizado

- Falla de repuestos al raíz de uso incorrecto, falta de mantenimiento, lubricación o modificación.
- Daños ocurridos a raíz de mal transporte, accidentes, incendios o cualquier daño como resultado de servicio por personas no autorizados o instalaciones incorrectas de conexiones eléctricas o neumáticas.
- Desgaste normal de piezas como correas, anillos de goma, cuchillas, agujas, etc.
- Ajustes de la máquina en relación a las aplicaciones de costura y/o la operación en general de la máquina.
- Gastos de Reparaciones fuera de las instalaciones de AAC,
- Pérdida de tiempo, ingresos potenciales, y/o ganancias.
- Daños personales y/o daños a la propiedad como resultado de la operación de este equipo.



---

**NOTES**

From the library of: Diamond Needle Corp

ITEM NO.	Hardware shown/QTY.	PART NUMBER	DESCRIPTION
1	1	11367	TICK CAROUSEL, 12 ROLL
2	2	1367014	MOUNT, SUPPORT
3	10	1367035	ROD CRADLE ASM
4	10	1367040	ROD, ROLL HOLDER, 2.5"OD
5	20	1367043	CONE, MATERIAL ROLL
6	2	1367046	BRACKET, SUPPORT
7	2	1367055	ROLL ANTI-SWAY BRACKET

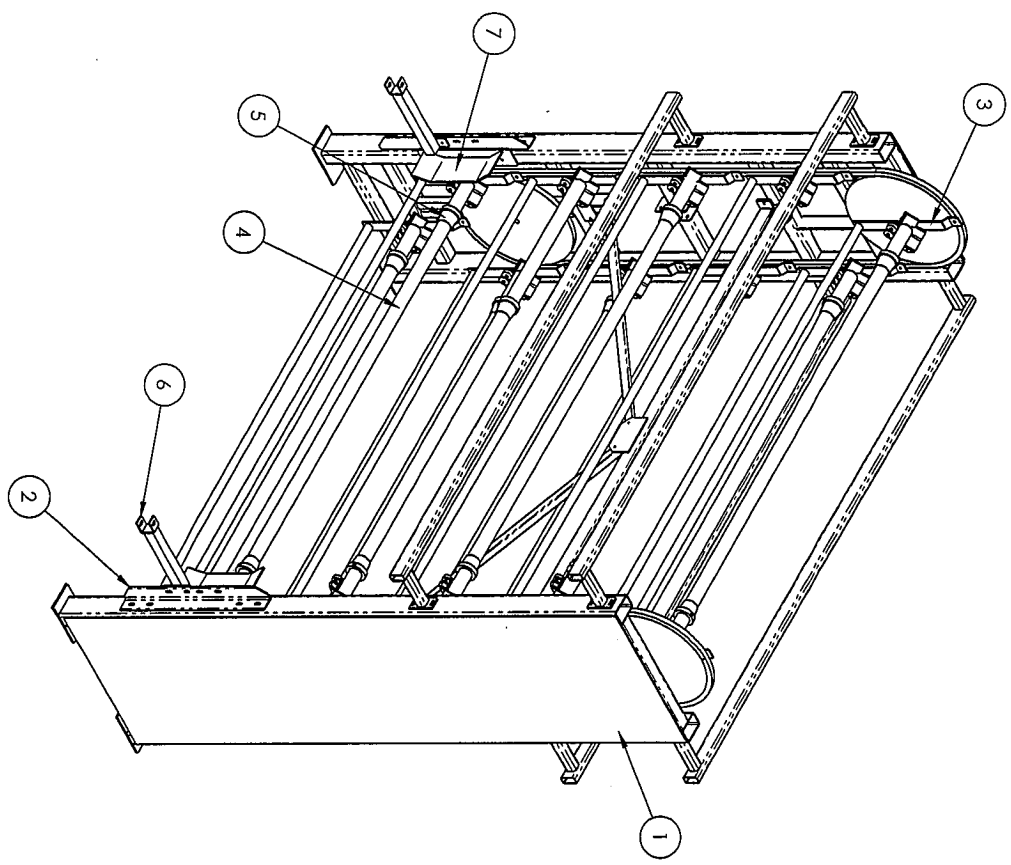

311367/11367510

136408

FINISH	DEFAULTS	ATLANTA ATTACHMENT COMPANY
RESISTANCE	COMPONENT	NAME: TICK CAROUSEL LIBR015P
REWORK	ASSEMBLY	SERIAL: ROD SPINDLES FOR LASER
REWORK	ASSEMBLY	WARRANTY: NONE
REWORK	ASSEMBLY	DATE: 11/26/2010
REWORK	ASSEMBLY	QTY: 9002173
REWORK	ASSEMBLY	LOT: 0

136408

DATE: 7/23/2008 TIME: 10:42:30 AM

YOUR USE OF THESE MATERIALS SERVES AS AN ACKNOWLEDGMENT OF THE CONFIDENTIAL AND PROPRIETARY NATURE OF THESE MATERIALS AND YOUR DUTY NOT TO MAKE ANY UNAUTHORIZED USE OR DISCLOSURE OF THESE MATERIALS.

ITEM NO.	Hardware Shown/QTY.	PART NUMBER	DESCRIPTION
1	1	1367037	CRADLE ASM, ROD HOLDER
2	6	1367051	GLUIDE, ROUND, TUBE
3	6	SSAS024048	SHOULDER BOLT, 3/8X3/4X5/16-18
4	6	NNH5/16-18	5/16-18 HEX NUT

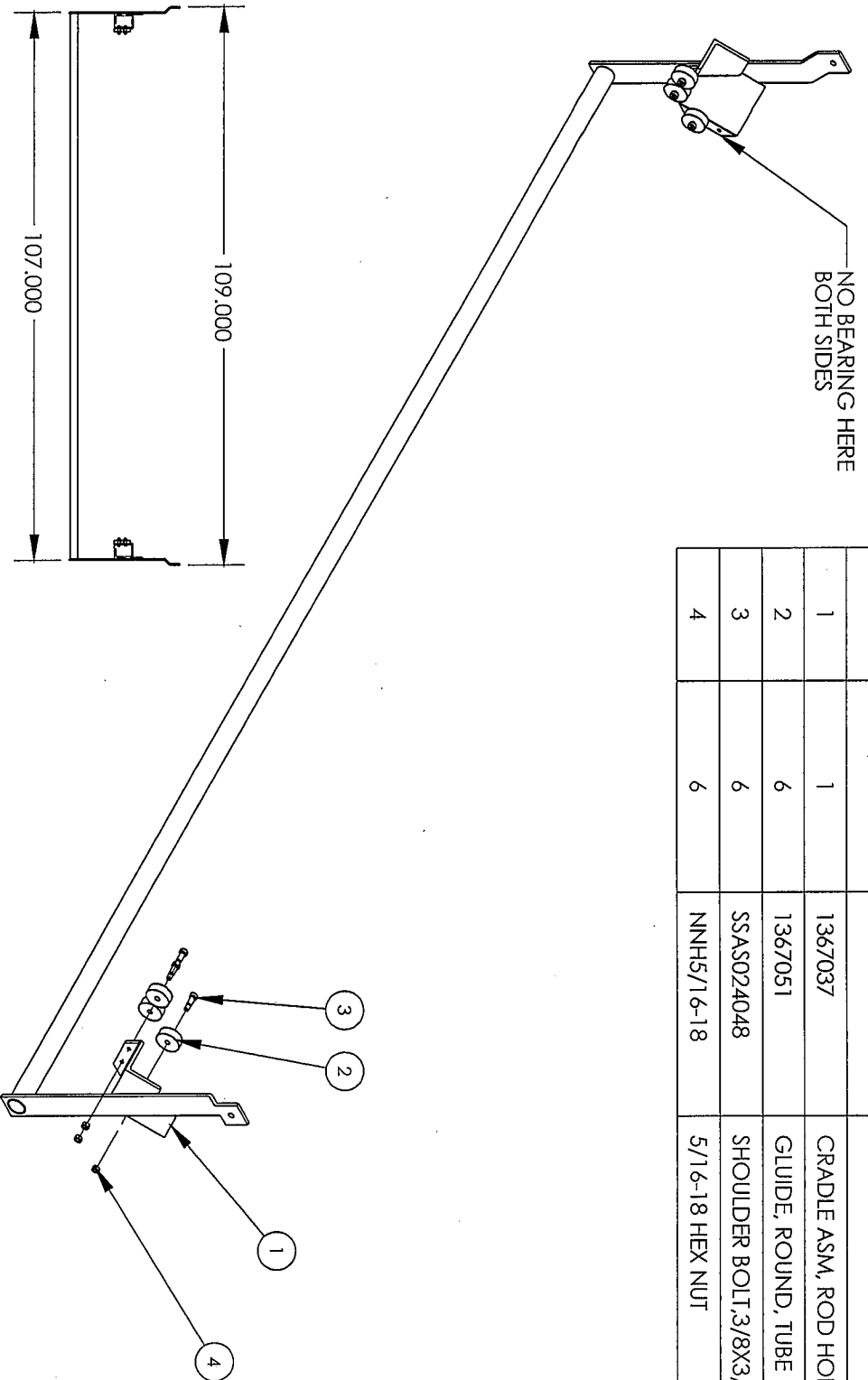

SN 1367\1367035

THE INFORMATION ON THIS DRAWING IS THE INTELLECTUAL PROPERTY OF ATLANTA ATTACHMENT COMPANY AND ITS AFFILIATES. THIS DRAWING MAY NOT BE COPIED IN ANY FORM WHATSOEVER. THIS INFORMATION MAY NOT BE USED BY ANY UNAUTHORIZED PERSON OR COMPANY. IN ADDITION TO ANY CONFIDENTIALITY AND NON-DISCLOSURE OBLIGATIONS THAT CURRENTLY EXIST BETWEEN YOU AND ATLANTA ATTACHMENT COMPANY, YOUR USE OF THESE MATERIALS SERVES AS AN ACKNOWLEDGMENT OF THE CONFIDENTIAL AND PROPRIETARY NATURE OF THESE MATERIALS AND YOUR DUTY NOT TO MAKE ANY UNAUTHORIZED USE OR DISCLOSURE OF THESE MATERIALS.



158-08

REV	DATE	BY	CHK	DESCRIPTION
1	2008	409	DR	CR

FINISH	PLATE/CLEAN	DEFAULTS	COUNTERSINKS	NAME	ROD CRADLE ASM
	BURR BRUSH			2nd DIS	
	HEAT TREAT			MATERIAL	NOTED
	SAND BLAST			ASSEMBLY	1367
	BLUFF			DES BY	MW
	PAINT			DR BY	M. WITCHER
	GEAR CHROME			CK BY	RA
	OTHER			SCALE	1:15

SHEET 1 OF 1	ATLANTA ATTACHMENT COMPANY	PART NO. 1367035	REV 1
		DRAWING NO. 1367035	
		DATE 7/16/2008	DWG SIZE A WEIGHT 25.651053



ITEM NO.	Hardware Shown/QTY.	PART NUMBER	DESCRIPTION
1	1	1367040	ROD, ROLL HOLDER, 2.5"OD
2	2	1367043	CONE, MATERIAL ROLL
3	2	SSSCM8X16	SCREW, SOCC CAP, M8X16

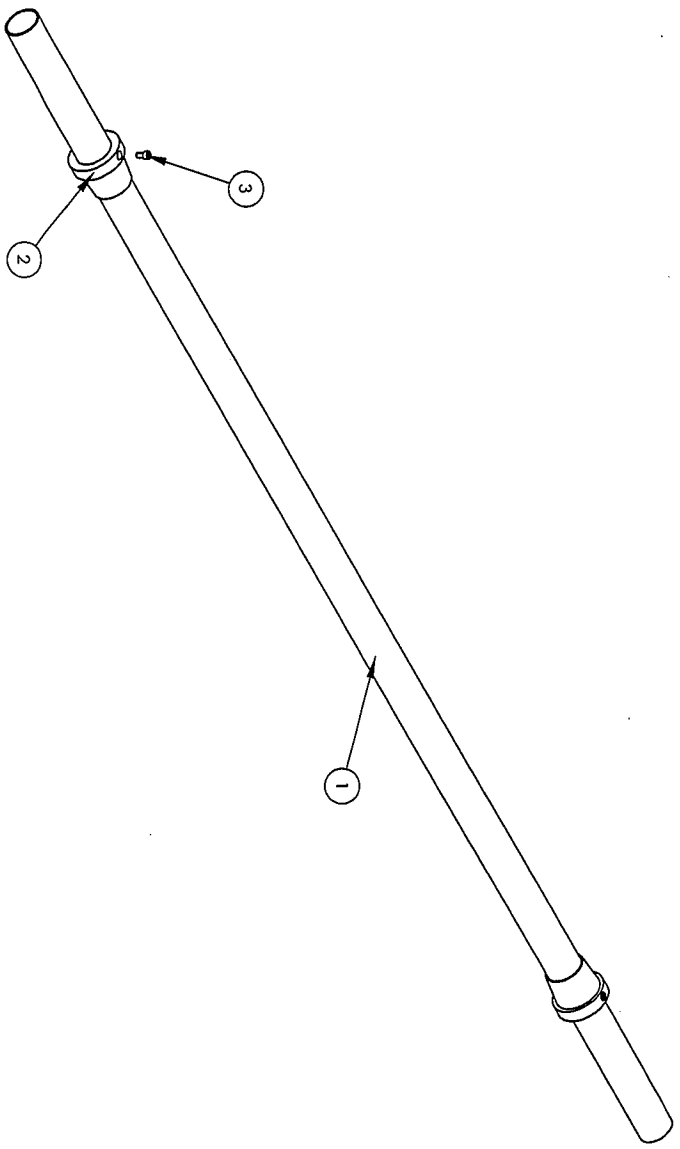

SN 1367A 1367060

**RESEARCH & DEVELOPMENT**

WORK ORDER:	QTY. FOR TRIAL	1
MACHINE TIME:	QTY. PER ASSY.	10
DESIGN TIME:		
NEEDED BY:		6/10/2013
CHECKED BY:		
RETURN TO:	Preston Dodder	

THE INFORMATION ON THIS DRAWING IS THE INTELLECTUAL PROPERTY OF ATLANTA ATTACHMENT COMPANY AND ITS AFFILIATES. THIS DRAWING MAY NOT BE COPIED IN ANY FORM WHATSOEVER. THIS INFORMATION MAY NOT BE USED BY ANY UNAUTHORIZED PERSON OR COMPANY, IN ADDITION TO ANY CONFIDENTIALITY AND NON-DISCLOSURE OBLIGATIONS THAT CURRENTLY EXIST BETWEEN YOU AND ATLANTA ATTACHMENT COMPANY. YOUR USE OF THESE MATERIALS SERVES AS AN ACKNOWLEDGMENT OF THE CONFIDENTIAL AND PROPRIETARY NATURE OF THESE MATERIALS AND YOUR DUTY NOT TO MAKE ANY UNAUTHORIZED USE OR DISCLOSURE OF THESE MATERIALS.



<b>FINISH</b>	<b>DEFAULTS</b>	<b>ATLANTA ATTACHMENT COMPANY</b>
BLANK/CLEAN BARE BRASS BLACK OXIDE SAND BLAST BLUE CONFORMAL COATING ENAMEL INTRINSIC NONE	COMMENTS  NAME: SUPP/ORT ROD WITH COLLARS Dwg No. 1367060 MATERIAL: 1367S10 DES. BY: Preston Dodder Dwg No. 1367060 C.C. BY: Preston Dodder SCALE: 1:1 DATE: 6/10/2013 DWG. SHEET: B VER: 0	NAME: SUPP/ORT ROD WITH COLLARS Dwg No. 1367060 MATERIAL: 1367S10 DES. BY: Preston Dodder Dwg No. 1367060 C.C. BY: Preston Dodder SCALE: 1:1 DATE: 6/10/2013 DWG. SHEET: B VER: 0